

Laser Displacement Sensor ZP-L

Premium detection stability and optimal usability for Laser Displacement Sensors

- Sensing performance delivering stable detection with initial configuration left intact
- User interface requiring no manuals for easy understanding
- Support software allowing quick test without loggers



For the most recent information on models that have been certified for safety standards, refer to your OMRON website.

System configuration

Basic configuration

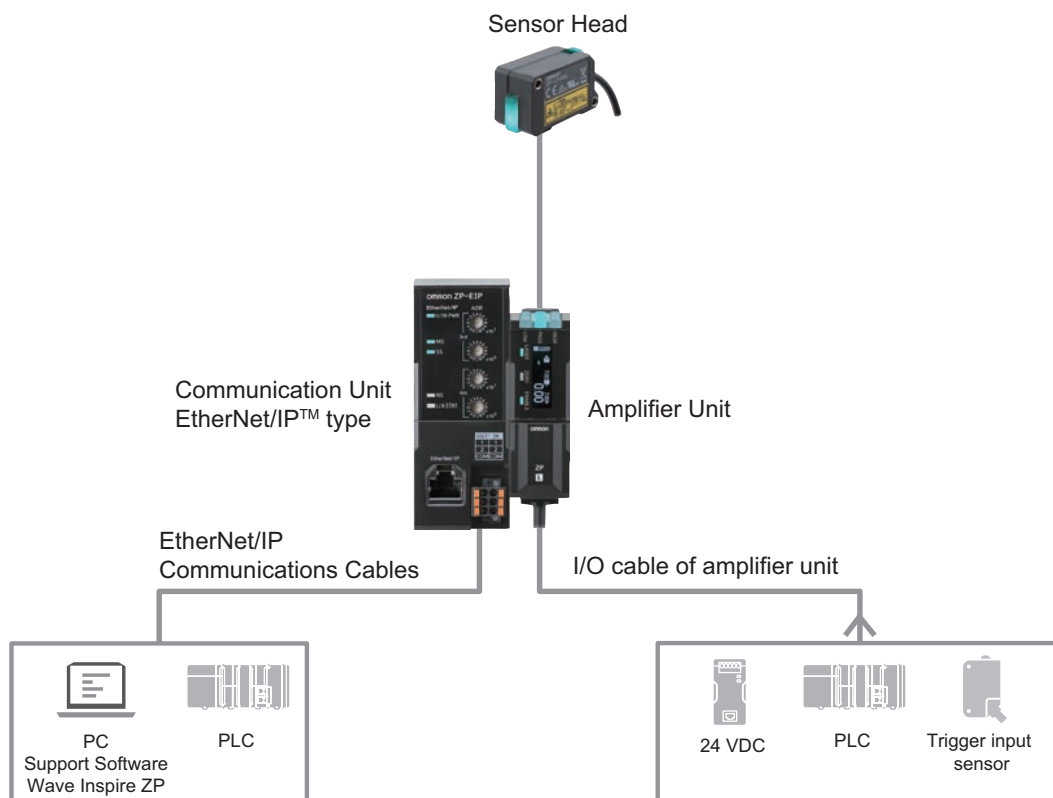

Product	Description
Sensor Head	We offer an extensive lineup from which you can select your product based on measurement distance, beam shape, and resolution.
Amplifier Unit	One amplifier unit is required for each sensor head.
Communication Unit	Required for communication with PC/PLC.
EtherNet/IP Communications Cables	Required for connection with PC/PLC.
Support Software Wave Inspire ZP	Download free from below URL. https://www.ia.omron.com/zp_tool

Configuration with multiple units connected

We offer two lines of amplifier unit products: master units and slave units. When using several sensor units, use them with slave units to save costs and wiring. Up to 16 amplifier units can be connected together (one master unit, 15 slave units).

When having judgment output from each amplifier unit
 1 master unit,
 N slave units (models with input/output:
 ZP-L3500/-L3510/-L3550/-L3560)

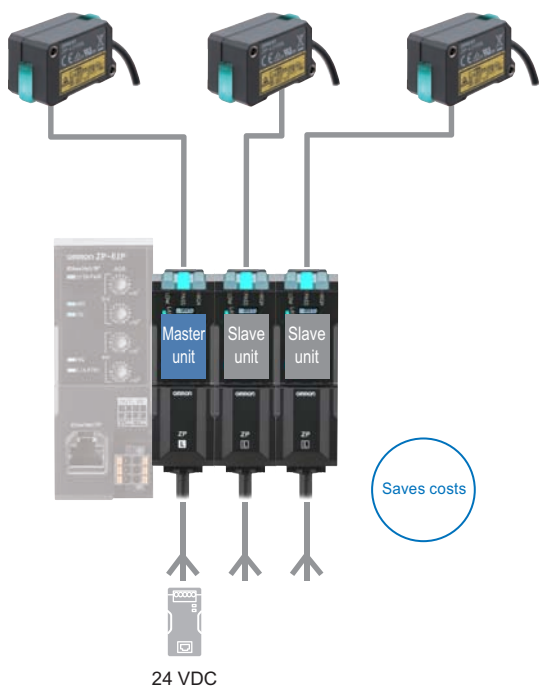

When retrieving measurement values using communication unit
 1 master unit,
 N slave units (model without input/output: ZP-L3590)

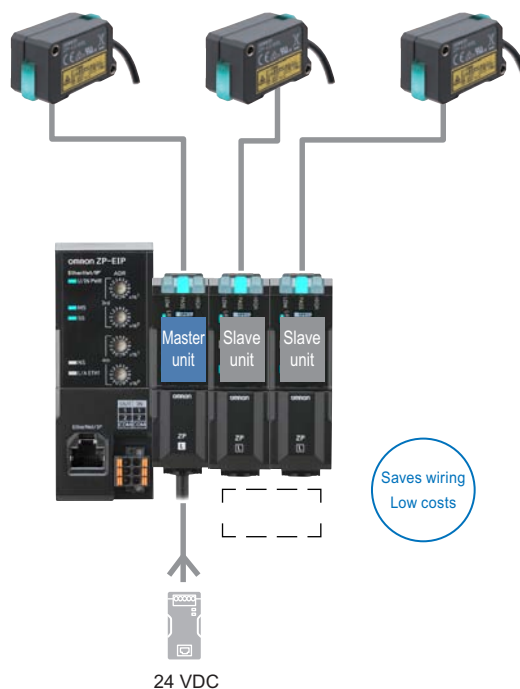

Product	Description
Amplifier unit master unit	First amplifier unit must be master unit. Power supply is connected to master unit only.
Amplifier unit slave unit	Up to 15 units can be connected. There are three types with different combinations of analog output, judgment output, and external input.
Communication Unit	Use as needed.



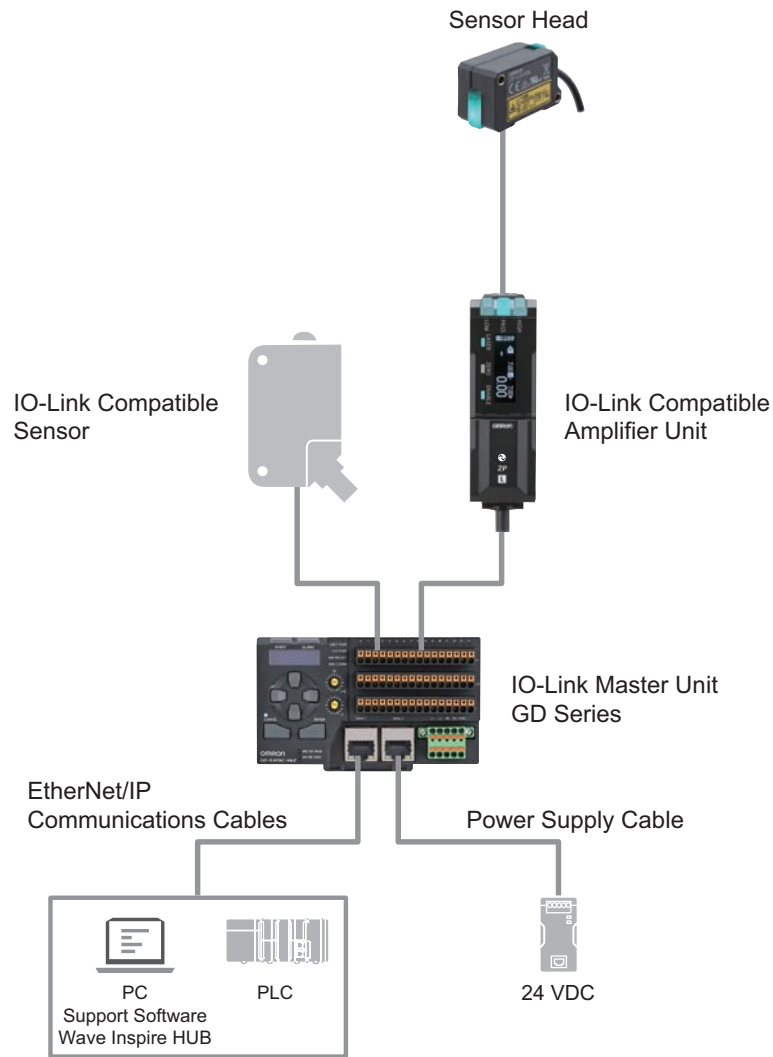



Configuration for using IO-Link communications

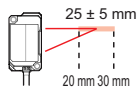
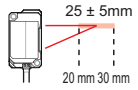
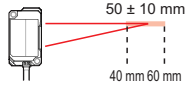
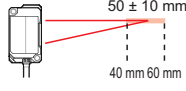
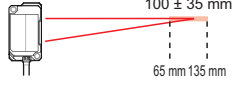
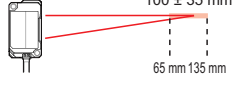

Product	Description
Sensor Head	We offer an extensive lineup from which you can select your product based on measurement distance, beam shape, and resolution.
IO-Link Compatible Amplifier Unit	One amplifier unit is required for each sensor head. There are discrete wire cable pull-out type and M12 connector cable pull-out type.
IO-Link Master Unit	In this example, the GD series is shown.
Support Software Wave Inspire HUB	Support Software for the IO-Link Master Unit GD series. Download free from below URL. https://www.ia.omron.com/gd_tool

Ordering Information

Sensor Head

Appearance	Optical system	Beam shape	Measurement distance	Resolution*	Cable length	Model
	Diffuse-reflective	Line beam		0.5 μm	0.2 m	ZP-LS025L 0.2M
					2 m	ZP-LS025L 2M
		Spot beam		0.6 μm	0.2 m	ZP-LS025S 0.2M
					2 m	ZP-LS025S 2M
		Line beam		0.7 μm	0.2 m	ZP-LS050L 0.2M
					2 m	ZP-LS050L 2M
		Spot beam		0.8 μm	0.2 m	ZP-LS050S 0.2M
					2 m	ZP-LS050S 2M
		Line beam		1.2 μm	0.2 m	ZP-LS100L 0.2M
					2 m	ZP-LS100L 2M
Spot beam		1.3 μm	0.2 m	ZP-LS100S 0.2M		
			2 m	ZP-LS100S 2M		
	Diffuse-reflective	Line beam		4 μm	0.2 m	ZP-LS300L 0.2M
					2 m	ZP-LS300L 2M
		Spot beam		4 μm	0.2 m	ZP-LS300S 0.2M
					2 m	ZP-LS300S 2M
		Line beam		14 μm	0.2 m	ZP-LS600L 0.2M
					2 m	ZP-LS600L 2M
		Spot beam		14 μm	0.2 m	ZP-LS600S 0.2M
					2 m	ZP-LS600S 2M



* This shows the width of the variation of measured values when OMRON's standard target (white diffuse object) is measured at a reference distance with a measurement cycle of 1 ms and an average rate of 128 times.

Note: Sensor heads listed on this data sheet use class 2 lasers, but we offer products with class 1 lasers as well, the model names of which end with the letter "C" followed by cable length (example: ZP-LS025LC 2M).



Using different beam shapes

Amplifier Unit

Appearance	Master/Slave *1	Analog output	Judgment output *2	External input *3	Input/output type	Model
	Master unit	Yes	Yes	Yes	NPN	ZP-L3000
					PNP	ZP-L3050
		No	Yes	Yes	NPN	ZP-L3010
	Slave unit	Yes	Yes	Yes	PNP	ZP-L3060
					NPN	ZP-L3500
		No	Yes	Yes	PNP	ZP-L3550
	Slave unit	No	No	No	—	ZP-L3590

*1. First amplifier unit must be master unit.

In a system with multiple amplifier units connected together, there can only be one master unit.

Power supply connection is required for master unit only. All power supplied to slave and communication units is supplied from master unit.

*2. HIGH/PASS/LOW

*3. Zero reset, LD-off, timing, reset, bank

IO-Link Compatible Amplifier Unit



Appearance	Connection method	Analog output	Judgment output *2	External input *3	Input/output type	Model
	Discrete wire cable pull-out type	No	Yes (switching) *1	Yes (switching) *1	NPN/PNP (switching)	ZP-L3930-IL3
	M12 connector cable pull-out type				NPN/PNP (switching)	ZP-L3931-IL3

*1. Judgment output and external input can be switched via settings.

*2. HIGH/PASS/LOW

*3. Zero reset, LD-off, timing, reset, bank

Communication Unit

Appearance	Communication type	Connected devices	Model
	EtherNet/IP™ No-protocol (TCP)	PLCs and PCs from different manufacturers	ZP-EIP
	RS-232C	PLCs and PCs from different manufacturers	ZP-RSA

To use support software Wave Inspire ZP connect your sensor to your PC using the communication unit.

Wave Inspire ZP can be downloaded for free from the URL below.

https://www.ia.omron.com/zp_tool

Wave Inspire ZP is a setup support tool. Please note the following before use.

- (1) OMRON assumes no responsibility for damage caused by any malfunctioning of this software, whether directly or indirectly, or caused by the effects of such malfunctioning.
- (2) OMRON assumes no responsibility for any damage incurred by the customer due to use of this software.

How to connect amplifier units and communication units

How to connect an IO-Link Compatible Amplifier Unit



EtherNet/IP



RS-232C











Discrete wire cable pull-out type



M12 connector cable pull-out type

Accessories (sold separately)
Sensor head - amplifier unit extension cable

Cable specifications	Cable connection direction	Assembly tutorial video	Cable length	Model
Normal cable	Amplifier unit side: Straight Sensor head side: Straight		1 m	XS3W-M421-401-R
			2 m	XS3W-M421-402-R
			5 m	XS3W-M421-405-R
			10 m	XS3W-M421-410-R
			20 m	XS3W-M421-420-R
	Amplifier unit side: L-shaped Sensor head side: L-shaped		1 m	XS3W-M422-401-R
			2 m	XS3W-M422-402-R
			5 m	XS3W-M422-405-R
			10 m	XS3W-M422-410-R
			20 m	XS3W-M422-420-R
	Amplifier unit side: Straight Sensor head side: L-shaped		1 m	XS3W-M423-401-R
			2 m	XS3W-M423-402-R
			5 m	XS3W-M423-405-R
			10 m	XS3W-M423-410-R
			20 m	XS3W-M423-420-R
	Amplifier unit side: L-shaped Sensor head side: Straight		1 m	XS3W-M424-401-R
2 m			XS3W-M424-402-R	
5 m			XS3W-M424-405-R	
10 m			XS3W-M424-410-R	
20 m			XS3W-M424-420-R	
Robot cable	Amplifier unit side: Straight Sensor head side: Straight		1 m	XS3W-M421-401-PR
			2 m	XS3W-M421-402-PR
			5 m	XS3W-M421-405-PR
			10 m	XS3W-M421-410-PR
			20 m	XS3W-M421-420-PR
	Amplifier unit side: L-shaped Sensor head side: L-shaped		1 m	XS3W-M422-401-PR
			2 m	XS3W-M422-402-PR
			5 m	XS3W-M422-405-PR
			10 m	XS3W-M422-410-PR
			20 m	XS3W-M422-420-PR
	Amplifier unit side: Straight Sensor head side: L-shaped		1 m	XS3W-M423-401-PR
			2 m	XS3W-M423-402-PR
			5 m	XS3W-M423-405-PR
			10 m	XS3W-M423-410-PR
			20 m	XS3W-M423-420-PR
	Amplifier unit side: L-shaped Sensor head side: Straight		1 m	XS3W-M424-401-PR
2 m			XS3W-M424-402-PR	
5 m			XS3W-M424-405-PR	
10 m			XS3W-M424-410-PR	
20 m			XS3W-M424-420-PR	











Note: You cannot use multiple extension cables connected together.

<Key points in selecting your extension cable>











- The pre-wired cable of the sensor head is a standard cable. In cases where cable bending is necessary, connect an extension robot cable, and bend the extension cable. We recommend you use a 0.2-m cable for your sensor head.
- Using the L-shaped cable connector for amplifier unit connection allows you to secure space around the area of connection.

ZP-L

Mounting bracket For ZP-LS025/-LS050/-LS100

Appearance	Illustration of installed bracket	Assembly tutorial video	Model
L-shaped Mounting Bracket 			ZP-XL1
Rear Mounting Bracket 			ZP-XL2
Flexible Mounting Bracket 			ZP-XL5
Post 50 mm 			E39-L262
Post 100 mm 			E39-L263

For ZP-LS300/-LS600

Appearance	Illustration of installed bracket	Assembly tutorial video	Model
L-shaped Mounting Bracket 			ZP-XL3
Rear Mounting Bracket 			ZP-XL4
Flexible Mounting Bracket 			ZP-XL6
Post 50 mm 			E39-L262
Post 100 mm 			E39-L263

Recommended EtherNet/IP Communications Cables

For EtherNet/IP, required specification for the communications cables varies depending on the baud rate. For 100BASE-TX/10BASE-T, use a straight or cross STP (shielded twisted-pair) cable of category 5 or higher.

Cable with Connectors

Item		Recommended manufacturer	Cable length (m)	Model
Wire gauge and number of pairs: AWG26, 4-pair cable Cable sheath material: PUR	Cable with Connectors on Both Ends (RJ45/RJ45) Standard RJ45 plugs *1 Cable color: Yellow *2 EtherNet/IP (10BASE/100BASE)	OMRON	0.3	XS6W-6PUR8SS30CM-YF
			0.5	XS6W-6PUR8SS50CM-YF
			1	XS6W-6PUR8SS100CM-YF
			2	XS6W-6PUR8SS200CM-YF
			3	XS6W-6PUR8SS300CM-YF
			5	XS6W-6PUR8SS500CM-YF
	Cable with Connectors on Both Ends (RJ45/RJ45) Rugged RJ45 plugs *1 Cable color: Light blue EtherNet/IP (10BASE/100BASE)		0.3	XS5W-T421-AMD-K
			0.5	XS5W-T421-BMD-K
			1	XS5W-T421-CMD-K
			2	XS5W-T421-DMD-K
			5	XS5W-T421-GMD-K
			10	XS5W-T421-JMD-K

*1. Cables with standard RJ45 plugs are available in the following lengths: 0.2 m, 0.3 m, 0.5 m, 1 m, 1.5 m, 2 m, 3 m, 5 m, 7.5 m, 10 m, 15 m, 20 m.

Cables with rugged RJ45 plugs are available in the following lengths: 0.3 m, 0.5 m, 1 m, 2 m, 3 m, 5 m, 10 m, 15 m.

For details, refer to the *Industrial Ethernet Connectors Catalog* (Cat. No. G019).

*2. Cable colors are available in yellow, green, and blue.

Cables/Connectors

Item		Recommended manufacturer	Model
Products for EtherNet/IP (100BASE-TX/10BASE-T)	Wire gauge and number of pairs: AWG22, 2-pair cable	Cable	Kuramo Electric Co. KETH-PSB-OMR *1
			JMACS Japan Co., Ltd. PNET/B *1
		RJ45 Assembly Connector 	OMRON XS6G-T421-1 *1

*1. We recommend you to use the above Cable and RJ45 Assembly Connector together.

ZP-L

Ratings and Performance

Sensor Head

Item	Specification						
	ZP-LS025L(C)	ZP-LS025S(C)	ZP-LS050L(C)	ZP-LS050S(C)	ZP-LS100L(C)	ZP-LS100S(C)	
Reference distance	25 mm		50 mm		100 mm		
Measurement distance	20 to 30 mm		40 to 60 mm		65 to 135 mm		
Light source	Red semiconductor laser						
Wavelength	660 nm						
Laser class	ZP-LS□L, ZP-LS□S: Class 2 (JIS/IEC/EN/FDA/GB) ZP-LS□LC, ZP-LS□SC: Class 1 (JIS/IEC/EN/FDA/GB)						
Laser power	ZP-LS□L, ZP-LS□S: 1 mW max. ZP-LS□LC, ZP-LS□SC: 0.376 mW max.						
Spot diameter *1	Approx. 50 × 1,000 μm	Approx. 50 μm dia.	Approx. 70 × 1,600 μm	Approx. 70 μm dia.	Approx. 130 × 2,900 μm	Approx. 120 μm dia.	
Linearity *2	Near side	±0.05% F.S. (±5 μm)	±0.1% F.S. (±10 μm)	±0.03% F.S. (±6 μm)	±0.075% F.S. (±15 μm)	±0.025% F.S. (±17.5 μm)	±0.07% F.S. (±49 μm)
		when used at 20 to 25 mm		when used at 40 to 50 mm		when used at 65 to 100 mm	
	Total area	±0.08% F.S. (±8 μm)	±0.125% F.S. (±12.5 μm)	±0.04% F.S. (±8 μm)	±0.1% F.S. (±20 μm)	±0.065% F.S. (±45.5 μm)	±0.085% F.S. (±59.5 μm)
when used at 20 to 30 mm		when used at 40 to 60 mm		when used at 65 to 135 mm			
Resolution (Repeatability) *3	0.5 μm	0.6 μm	0.7 μm	0.8 μm	1.2 μm	1.3 μm	
Temperature characteristics *4	0.01% F.S./°C		0.01% F.S./°C		0.01% F.S./°C		
Indicators	2 indicators (identified by color) HIGH (orange)/PASS (green)/LOW (orange), Out of range (white), Error (red), SETTING mode (blue)						
Ambient illuminance	Illuminance of light-receiving surface, Incandescent lamp: 10,000 lx max.						
Ambient temperature range	Operating: -10 to 50°C, Storage: -15 to 70°C (with no icing or condensation)						
Ambient humidity range	Operating and storage: 35% to 85% RH each (with no condensation)						
Dielectric strength	1,000 VAC 50/60 Hz for 1 min.						
Insulation resistance	20 MΩ min. (at 500 VDC)						
Vibration resistance	10 to 500 Hz, double amplitude 1.5 mm, 120 min. each in X, Y and Z directions						
Shock resistance	300 m/s ² , 3 times each in 6 directions along X, Y, and Z axes						
Degree of protection	IP67 (IEC60529)						
Connection method *5	Pre-wired Connector type (Standard cable length: 2 m/0.2 m)						
Material	Case and cover: Polybutylene terephthalate, Optical window: Glass, Threaded portion: SUS304, Cable: PVC						
Weight (Main unit only)	Approx. 90 g (Cable length: 2 m), Approx. 45 g (Cable length: 0.2 m)						
Accessories	Instruction manual, compliance sheet, FDA certification label, fixing screws (M3 × 30 mm. 2 screws), laser warning label (ZP-LS□L and ZP-LS□S models only)						

*1. This is the value (actual value) at the standard distance, which is defined as $1/e^2$ (13.5%) of the central light intensity.

*2. This shows the error of displacement output relative to the ideal line when OMRON's standard target (white diffuse object) is measured. Linearity and measured values may vary depending on the target object. F.S. refers to the entire measuring range (70 mm for ZP-LS100L).

*3. This shows the width of the variation of measured values when OMRON's standard target (white diffuse object) is measured at a reference distance with a measurement cycle of 1 ms and an average rate of 128 times.

*4. This is the value (typical value) measured at the reference distance, with the Sensor Head and OMRON's standard object (white diffuse object) fixed with an aluminum jig between them.

*5. This product is powered by the Laser Displacement Sensor Amplifier Unit (ZP-L3□□□).

Item	Specification				
	ZP-LS300L(C)	ZP-LS300S(C)	ZP-LS600L(C)	ZP-LS600S(C)	
Reference distance	300 mm		600 mm		
Measurement distance	150 to 450 mm		200 to 1,000 mm		
Light source	Red semiconductor laser				
Wavelength	660 nm				
Laser class	ZP-LS□L, ZP-LS□S: Class 2 (JIS/IEC/EN/FDA/GB) ZP-LS□LC, ZP-LS□SC: Class 1 (JIS/IEC/EN/FDA/GB)				
Laser power	ZP-LS□L, ZP-LS□S: 1 mW max. ZP-LS□LC, ZP-LS□SC: 0.376 mW max.				
Spot diameter *1	Approx. 340 × 2,800 μm	Approx. 310 μm dia.	Approx. 670 × 5,800 μm	Approx. 600 μm dia.	
Linearity *2	Near side	±0.03% F.S. (±90 μm)	±0.04% F.S. (±120 μm)	±0.06% F.S. (±480 μm)	±0.075% F.S. (±600 μm)
		when used at 150 to 300 mm		when used at 200 to 600 mm	
	Total area	±0.1% F.S. (±300 μm)	±0.125% F.S. (±375 μm)	±0.15% F.S. (±1,200 μm)	±0.2% F.S. (±1,600 μm)
		when used at 150 to 450 mm		when used at 200 to 1,000 mm	
Resolution (Repeatability) *3	4 μm		14 μm		
Temperature characteristics *4	0.01% F.S./°C		0.02% F.S./°C		
Indicators	2 indicators (identified by color) HIGH (orange)/PASS (green)/LOW (orange), Out of range (white), Error (red), SETTING mode (blue)				
Ambient illuminance	Illuminance of light-receiving surface, Incandescent lamp: 5,000 lx max.				
Ambient temperature range	Operating: -10 to 50°C, Storage: -15 to 70°C (with no icing or condensation)				
Ambient humidity range	Operating and storage: 35% to 85% RH each (with no condensation)				
Dielectric strength	1,000 VAC 50/60 Hz for 1 min.				
Insulation resistance	20 MΩ min. (at 500 VDC)				
Vibration resistance	10 to 500 Hz, double amplitude 1.5 mm, 120 min. each in X, Y and Z directions				
Shock resistance	300 m/s ² , 3 times each in 6 directions along X, Y, and Z axes				
Degree of protection	IP67 (IEC60529)				
Connection method *5	Pre-wired Connector type (Standard cable length: 2 m/0.2 m)				
Material	Case and cover: Polybutylene terephthalate, Optical window: Glass, Threaded portion: SUS304, Cable: PVC				
Weight (Main unit only)	Approx. 110 g (Cable length: 2 m), Approx. 70 g (Cable length: 0.2 m)				
Accessories	Instruction manual, compliance sheet, FDA certification label, fixing screws (M3 × 35 mm. 2 screws), laser warning label (ZP-LS□L and ZP-LS□S models only)				

- *1. This is the value (actual value) at the standard distance, which is defined as 1/e² (13.5%) of the central light intensity.
- *2. This shows the error of displacement output relative to the ideal line when OMRON's standard target (white diffuse object) is measured.
Linearity and measured values may vary depending on the target object.
F.S. refers to the entire measuring range (70 mm for ZP-LS100L).
- *3. This shows the width of the variation of measured values when OMRON's standard target (white diffuse object) is measured at a reference distance with a measurement cycle of 1 ms and an average rate of 128 times.
- *4. This is the value (typical value) measured at the reference distance, with the Sensor Head and OMRON's standard object (white diffuse object) fixed with an aluminum jig between them.
- *5. This product is powered by the Laser Displacement Sensor Amplifier Unit (ZP-L3□□□).

Amplifier Unit
Master unit ZP-L30□□0

Item	Specification				
	ZP-L3000	ZP-L3010	ZP-L3050	ZP-L3060	
Master/Slave unit	Master Unit				
I/O type	NPN		PNP		
Analog output *1	Current output	4 to 20 mA Maximum load resistance: 350 Ω	No analog output	4 to 20 mA Maximum load resistance: 350 Ω	No analog output
	Voltage output	±5 V, 1 to 5 V, 0 to 5 V Output impedance: 100 Ω		±5 V, 1 to 5 V, 0 to 5 V Output impedance: 100 Ω	
Control output *2	HIGH/PASS/LOW/ Error output Open collector output: 30 VDC, 50 mA max., Residual voltage: 2 V max. N.O./N.C. switchable				
External input	Zero reset, Laser OFF, Timing, Reset, BANK				
Measurement cycle	When ON: 0 V short-circuit or 1.2 V max. When OFF: Open (Leakage current: 0.1 mA max.)		When ON: Power supply voltage short-circuit or within -1.2 V of power supply voltage When OFF: Open (Leakage current: 0.1 mA max.)		
	125 μs/250 μs/500 μs/1 ms/2 ms/4 ms/20 ms/50 ms/100 ms switchable				
Maximum number of connected units	16 (15 slave units can be connected per master unit)				
Display	OLED display Judgment indicators: HIGH (orange/red), PASS (green/red), LOW (orange/red) Status indicators: LASER (green), ZERO (green), ENABLE (green)				
Power supply voltage *3	10 to 30 VDC, including 10% ripple (p-p)				
Power consumption *4	2,300 mW max.	2,000 mW max.	2,300 mW max.	2,000 mW max.	
Ambient temperature range	Operating: -10 to 50°C (standalone or multi-unit connection) Storage: -15 to 70°C (with no icing or condensation)				
Ambient humidity range	Operating and storage: 35% to 85% RH each (with no condensation)				
Dielectric strength	1,000 VAC 50/60 Hz for 1 min.				
Insulation resistance	20 MΩ min. (at 500 VDC)				
Vibration resistance	10 to 150 Hz, double amplitude 0.7 mm, 80 minutes each in X, Y, and Z directions				
Shock resistance	300 m/s ² , 3 times each in 6 directions along X, Y, and Z axes				
Degree of protection *5	IP40 (IEC60529)				
Connection method	Cable pull-out type (Standard cable length: 2 m)				
Material	Main unit case, operating section cover: Polycarbonate Cable: PVC				
Weight (Main unit only)	Approx. 160 g	Approx. 150 g	Approx. 160 g	Approx. 150 g	
Accessories	Instruction manual, compliance sheet				

*1. Select ±5 V, 1 to 5 V, 0 to 5 V, or 4 to 20 mA to use this.

*2. When six or more Amplifier Units are added including the master unit, use a load current of 20 mA/ch or less.

*3. Use a Class 2 power supply to supply power to this product. When six or more Amplifier Units are added including the master unit, use a power supply voltage of 20 to 30 V, including 10% ripple (p-p).

*4. This includes the power consumption of the Sensor Head. It does not include the load current of each output.

*5. For slave units, this indicates the degree of protection when connected.

Slave unit ZP-L35□0

Item	Specification				
	ZP-L3500	ZP-L3510	ZP-L3550	ZP-L3560	ZP-L3590
Master/Slave unit	Slave Unit				
I/O type	NPN		PNP		No I/O
Analog output *1	Current output	4 to 20 mA Maximum load resistance: 350 Ω	No analog output	4 to 20 mA Maximum load resistance: 350 Ω	No analog output
	Voltage output	±5 V, 1 to 5 V, 0 to 5 V Output impedance: 100 Ω		±5 V, 1 to 5 V, 0 to 5 V Output impedance: 100 Ω	
Control output *2	HIGH/PASS/LOW/ Error output Open collector output: 30 VDC, 50 mA max., Residual voltage: 2 V max. N.O./N.C. switchable				No control output
External input	Zero reset, Laser OFF, Timing, Reset, BANK				No external input
	When ON: 0 V short-circuit or 1.2 V max. When OFF: Open (Leakage current: 0.1 mA max.)		When ON: Power supply voltage short-circuit or within -1.2 V of power supply voltage When OFF: Open (Leakage current: 0.1 mA max.)		
Measurement cycle	125 μs/250 μs/500 μs/1 ms/2 ms/4 ms/20 ms/50 ms/100 ms switchable				
Maximum number of connected units	16 (15 slave units can be connected per master unit)				
Display	OLED display Judgment indicators: HIGH (orange/red), PASS (green/red), LOW (orange/red) Status indicators: LASER (Green), ZERO (Green), ENABLE (Green)				
Power supply voltage *3	Supplied by master unit				
Power consumption *4	2,300 mW max.	2,000 mW max.	2,300 mW max.	2,000 mW max.	
Ambient temperature range	Operating: -10 to 50°C (standalone or multi-unit connection) *6 Storage: -15 to 70°C (with no icing or condensation)				
Ambient humidity range	Operating and storage: 35% to 85% RH each (with no condensation)				
Dielectric strength	1,000 VAC 50/60 Hz for 1 min.				
Insulation resistance	20 MΩ min. (at 500 VDC)				
Vibration resistance	10 to 150 Hz, double amplitude 0.7 mm, 80 minutes each in X, Y, and Z directions				
Shock resistance	300 m/s ² , 3 times each in 6 directions along X, Y, and Z axes				
Degree of protection *5	IP40 (IEC60529)				
Connection method	Cable pull-out type (Standard cable length: 2 m)				None
Material	Main unit case, operating section cover: Polycarbonate Cable: PVC				Main unit case, operating section cover: Polycarbonate
Weight (Main unit only)	Approx. 150 g	Approx. 140 g	Approx. 150 g	Approx. 140 g	Approx. 70 g
Accessories	Instruction manual, compliance sheet				

*1. Select ±5 V, 1 to 5 V, 0 to 5 V, or 4 to 20 mA to use this.

*2. When six or more Amplifier Units are added including the master unit, use a load current of 20 mA/ch or less.

*3. Use a Class 2 power supply to supply power to this product. When six or more Amplifier Units are added including the master unit, use a power supply voltage of 20 to 30 V, including 10% ripple (p-p).

*4. This includes the power consumption of the Sensor Head. It does not include the load current of each output.

*5. This indicates the degree of protection when connected to a master unit.

*6. If the total number of connected amplifier units, including the master unit, is three or more and includes a ZP-L3500/-L3550, use the unit in an ambient temperature range (during operation) of -10 to 45°C.

IO-Link Compatible Amplifier Unit

ZP-L39□□-IL3

Item	Specification	
	ZP-L3930-IL3	ZP-L3931-IL3
I/O type	NPN/PNP switchable	
Control output *1	PASS/Smart Verification/OUT1 Invert/Error Output/Deactivated Open collector output: 50 mA max., Residual voltage: 2 V max. N.O./N.C. switchable	
External input	Zero Reset/Laser OFF/Timing Reset switchable <ul style="list-style-type: none"> • PNP is set When ON: Power supply voltage short-circuit or within -1.5 V of power supply voltage When OFF: Open (Leakage current: 0.1 mA max.) • NPN is set When ON: 0 V short-circuit or 1.5 V max. When OFF: Open (Leakage current: 0.1 mA max.) 	
Measurement cycle	125 μs/250 μs/500 μs/1 ms/2 ms/4 ms/20 ms/50 ms/100 ms switchable	
Maximum number of connected units	1 (cannot be connected with other amplifier units.)	
Display	OLED display Judgment indicators: HIGH (orange/red), PASS (green/red), LOW (orange/red) Status indicators: LASER (green), ZERO (green), ENABLE (green)	
Power supply voltage *2	10 to 30 VDC, including 10% ripple (p-p)	
Power consumption *3	2,000 mW max.	
Ambient temperature range	Operating: -10 to 50°C Storage: -15 to 70°C (with no icing or condensation)	
Ambient humidity range	Operating and storage: 35% to 85% RH each (with no condensation)	
Dielectric strength	1,000 VAC 50/60 Hz for 1 min.	
Insulation resistance	20 MΩ min. (at 500 VDC)	
Vibration resistance	10 to 150 Hz, double amplitude 0.7 mm, 80 minutes each in X, Y, and Z directions	
Shock resistance	300 m/s ² , 3 times each in 6 directions along X, Y, and Z axes	
Degree of protection	IP40 (IEC60529)	
Connection method	Discrete wire cable pull-out type (Standard cable length: 2 m)	M12 connector cable pull-out type (Standard cable length: 0.3 m)
Material	Main unit case, operating section cover: Polycarbonate Cable: PVC	
Weight (Main unit only)	Approx. 150 g	Approx. 90 g
IO-Link	IO-Link specifications	Ver.1.1
	Baud rate	COM3: 230.4 kbps
	Data length	PD size: 6 bytes, OD size: 2 bytes (M-sequence type: TYPE_2_V)
	Minimum cycle time	COM3: 1.1 ms
	Device profile	Smart Sensor profile (SSP3.2)
Accessories	Instruction manual, compliance sheet	

*1. Smart Verification, OUT1 Invert, and Error Output are supported only on Out2.

*2. For the power supply for this product, use a Class 2 power supply or a power supply from an IO-LINK master connected to a Class 2 power supply.

*3. This includes the power consumption of the Sensor Head. It does not include the load current of each output.

Main functions

Function name	Description
Measurement cycle	Set as needed according to workpiece reflectance, tilt, etc. You can also use the auto-configuration feature to automatically set the optimal measurement cycle for the workpiece being measured.
Average rate	Set as needed according to measurement value stability.
Calculation	Enables calculation between multiple sensor heads and amplifier units. Provides addition and subtraction features, which you can use to measure level difference, thickness, etc. Calculation is performed by the master unit.
Analog output	Allows you to change analog output to voltage output and current output.
Analog scaling	Function for adjusting analog output against measurement results. Use, for example, when you want to present slight changes in displacement as large changes in analog output.
Measurement scaling	Function for applying correction to measurement results. Use when there is a difference between the expected result and measurement result, or when you want to apply a certain offset value.
Detection select	Allows you to select which surface to use for your measurement result, in cases where multiple measurement surfaces exist within the range of measurement. Use when measuring through glass, or detecting front/back surfaces of thin film.
Differential calculation	With this function, the measurement result is the difference between the current displacement amount and that of a given time earlier. Use when counting thin, board-like workpieces or when exclusively detecting sudden changes.
Hold function	With this function, the detection result is the feature value for the specified period. You can select which feature value to extract, e.g., the peak value (peak hold), the bottom value (bottom hold), the range of change (peak-to-peak hold), and so forth.
Timer mode	Allows you to delay upon changes in judgment output, or turn PASS output ON for a given period. Use when the judgment output changes so rapidly that upper-level devices cannot receive the signals.
Synchronization	Allows you to specify sensor head measurement timing. By staggering measurement timing, you can prevent mutual interference between sensors.
BANK change	Allows you to save/load sensor settings to the BANK. This function lets you change multiple settings (e.g., measurement cycles and threshold values) at once, which is useful in product changeovers, etc.

Communication Unit

ZP-EIP

General Specifications

Item	Specification
	ZP-EIP
Sensor that can be connected	ZP-series Amplifier Unit
Power supply voltage	10 to 30 VDC, including 10% ripple (p-p) (supplied from Amplifier Unit)
Power consumption	1,500 mW max. (not including Amplifier Unit)
Indicators	MS (Green/Red), NS (Green/Red), L/A ETH1 (Green), U/IN PWR (Green), SS (Green/ Red)
External input	Mode 1: Control input for Communication Unit buffering (2 inputs) Mode 2: Cuing information input (2 inputs) • DC input method Input voltage: 10 to 30 VDC Input current: 8 mA typical (24 VDC) ON voltage/current: 8.8 V min./2 mA min. OFF voltage/OFF current: 4 V max./0.5 mA max.
Control output	Communication Unit buffering status output (2 outputs) • Transistor output method Output voltage: 10 to 30 VDC Maximum load current: 50 mA ON residual voltage: 2 V max. OFF leakage current: 0.1 mA max.
Ambient temperature range	Operating: -10 to 50°C, Storage: -15 to 70°C (with no icing or condensation)
Ambient humidity range	Operating and storage: 35% to 85% (with no condensation)
Vibration resistance	10 to 150 Hz, double amplitude 0.7 mm, 80 minutes each in X, Y, and Z directions
Shock resistance	300 m/s ² , 3 times each in 6 directions along X, Y, and Z axes
Dielectric strength	1,000 VAC, 50/60 Hz for 1 minute
Insulation resistance	20 MΩ min. (at 500 VDC)
Maximum number of connected sensors	16 units max.
Degree of protection *1	IP20 (IEC60529)
Material	Polycarbonate
Weight (Main unit only)	Approx. 85 g
Accessories	Instruction manual, compliance sheet, End Plates (2)

*1. This indicates the degree of protection when connected to an Amplifier Unit.

EtherNet/IP Communications Specifications

Item		Specification
		ZP-EIP
Communications protocols		EtherNet/IP protocol <ul style="list-style-type: none"> • Implicit messages (Class1) • Explicit messages (Class 3, UCMM)
Modulation		Baseband
Link speed		10 Mbps or 100 Mbps
Ethernet physical layer *1		100BASE-TX or 10BASE-T (100BASE-TX is recommended.)
Ethernet switch		Layer-2 switch
Transmission media		Category 5 or higher twisted-pair cable (Recommended cable: double-shielded cable with aluminum tape and braiding)
Transmission distance		100 m or less (Distance between nodes and between hub and node)
Topology		Star, tree
Number of connected Units		<ul style="list-style-type: none"> • Star No restrictions • Tree There is no restrictions in the number of cascade connections when an Ethernet switch is used.
EtherNet/IP tag data links	Number of connections *2	1 (Point to Point)
	Packet Interval (RPI)	1 to 10,000 ms
	Allowed communications bandwidth per Unit	4,000 pps
Explicit message	Class 3 (number of connections) *2	5
	UCMM (unconnected) *2	Supported
EtherNet/IP I/O connection size		Input: 276 bytes max. (including input data, status, and unused areas) Output: 24 bytes max. (including output data and unused areas)
Support functions	Supported services	Tag data link, CIP message communications, automatic clock adjustment (NTP/SNTP client), BOOTP client, DHCP client
	IP address conflict detection	Provided

*1. If tag data links are used, use 100BASE-TX.

*2. The maximum number of connections is 10 when tag data links (Class 1), Class 3, and UCMM are used simultaneously.

ZP-RSA General Specifications

Item	Specification
Sensor that can be connected	ZP-series Amplifier Unit
Power supply voltage	10 to 30 VDC, including 10% ripple (p-p) (supplied from Amplifier Unit)
Power consumption	700 mW max. (not including Amplifier Unit)
Indicators	MS (Green/Red), SS (Green/Red), RD (Green), SD (Green)
External input	Request input When ON: 0 V short-circuit or 1.2 V max. When OFF: Open (Leakage current: 0.1 mA max.)
Ambient temperature range	Operating: -10 to 50°C Storage: -15 to 70°C (with no icing or condensation)
Ambient humidity range	Operating and storage: 35% to 85% RH each (with no condensation)
Vibration resistance	10 to 150 Hz, double amplitude 0.7 mm, 80 minutes each in X, Y, and Z directions
Shock resistance	300 m/s ² , 3 times each in 6 directions along X, Y, and Z axes
Dielectric strength	1,000 VAC, 50/60 Hz for 1 minute
Insulation resistance	20 MΩ min. (at 500 VDC)
Maximum number of connected sensors	16 units max.
Degree of protection *1	IP20 (IEC60529)
Material	Polycarbonate
Weight (Main unit only)	Approx. 75 g
Accessories	Instruction manual, compliance sheet, End Plates (2)

*1. This indicates the degree of protection when connected to an Amplifier Unit.

RS-232C Communications Specifications

Item	Specification	
Communications port	RS-232C (terminal block)	
Communications method	Full duplex	
Synchronization method	Start/stop synchronization	
Transmission code	ASCII	
Communications speed *1	2,400, 4,800, 9,600 (default) 19,200, 38,400, 57,600, or 115,200 bps	
Data bit length *1	7 bits or 8 bits (default)	
Parity check *1	None (default), Even, or Odd	
Stop bit length	1 bit	
Data delimiter	When receiving	CR or CR + LF automatically recognized
	When sending	CR + LF fixed

*1. Use the rotary switches on the front panel of the ZP-RSA to switch between settings. Turn OFF the power supply before changing the switch settings. The settings will be reflected when the power supply is turned ON next time.

Spot Diameter

ZP-LS025S

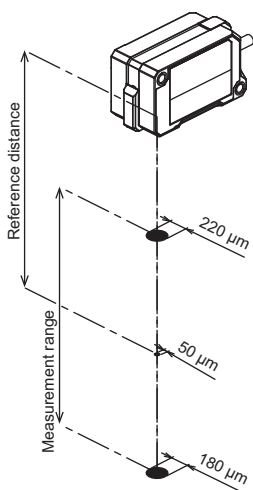

ZP-LS025L

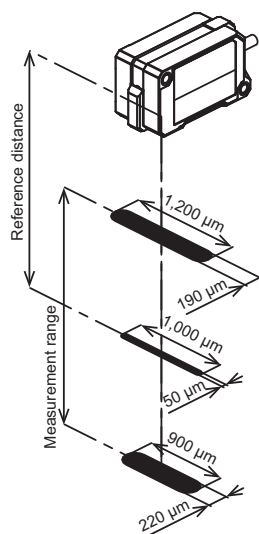

ZP-LS050S

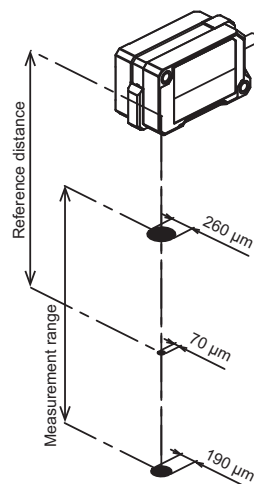

ZP-LS050L

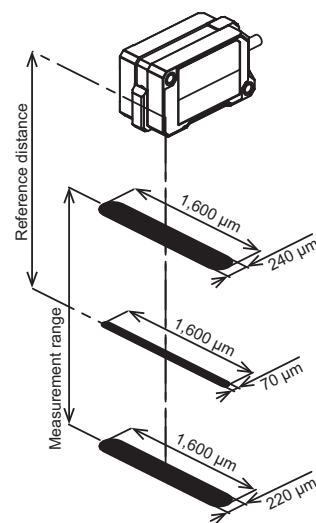

ZP-LS100S

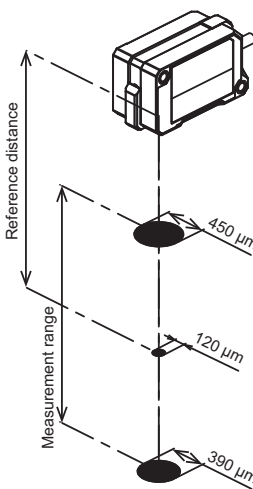

ZP-LS100L

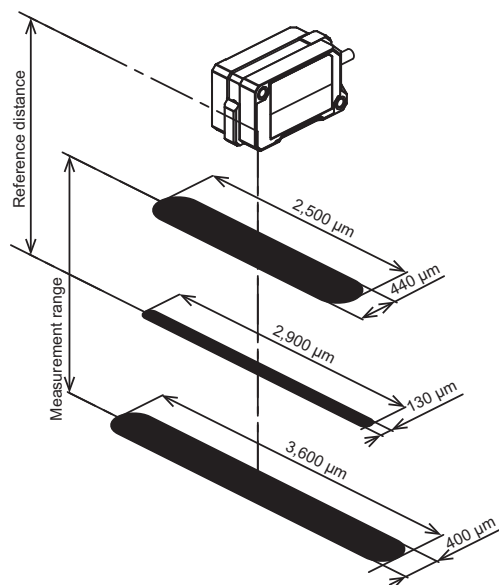

ZP-LS300S

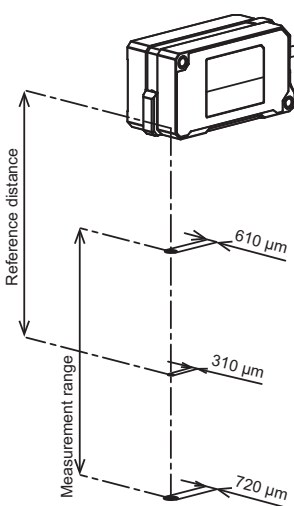

ZP-LS300L

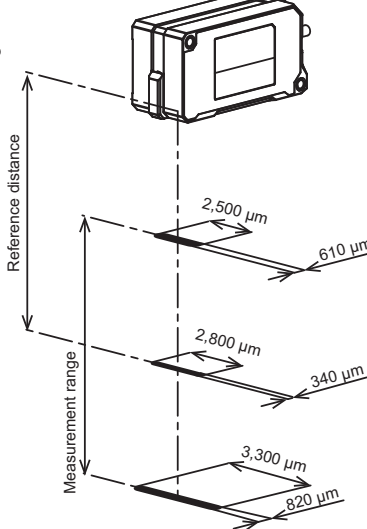

ZP-LS600S

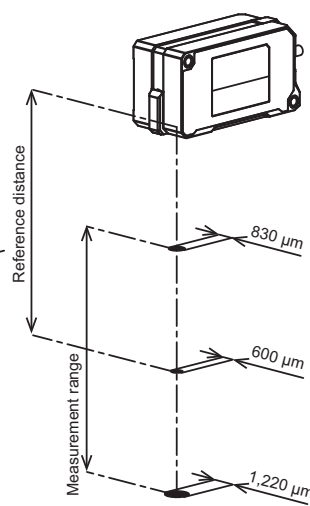

ZP-LS600L

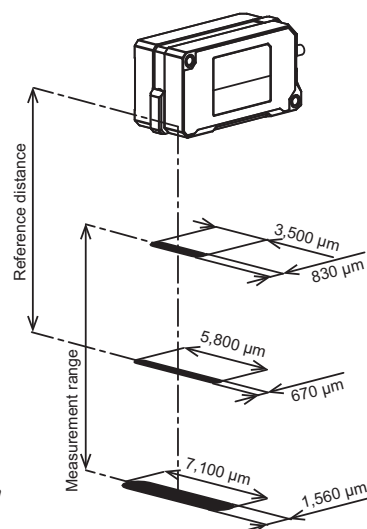

ZP-L

I/O Circuit Diagrams

ZP-L3000/ZP-L3010/ZP-L3500/ZP-L3510 (NPN Type)

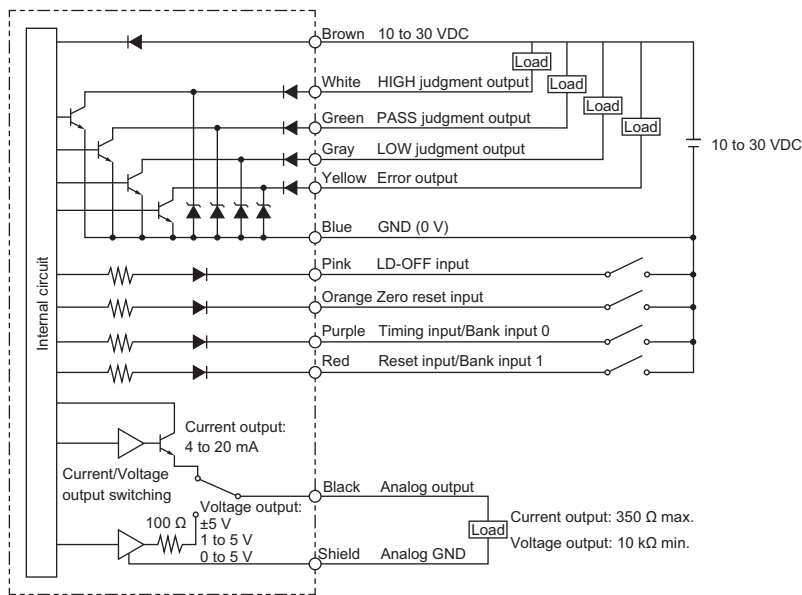

Item	ZP-L3000/ZP-L3500	ZP-L3010/ZP-L3510
Power consumption *1	2,300 mW max.	2,000 mW max.
Control output	Open collector output: 30 VDC, 50 mA max. (20 mA per channel when 5 or more additional slave units are installed) Residual voltage: 2 V max.	
External input	When ON: 0 V short-circuit or 1.2 V max. When OFF: Open (Leakage current: 0.1 mA max.)	
Analog output	Current output: 4 to 20 mA (Maximum load resistance: 350 Ω) Voltage output: ±5 V, 1 to 5 V, 0 to 5 V (Output impedance: 100 Ω)	No analog output

*1. This includes the power consumption of the Sensor Head. It does not include the load current of each output. The power consumption of the ZP-L3590 is 2,000 mW max.

ZP-L3050/ZP-L3060/ZP-L3550/ZP-L3560 (PNP Type)

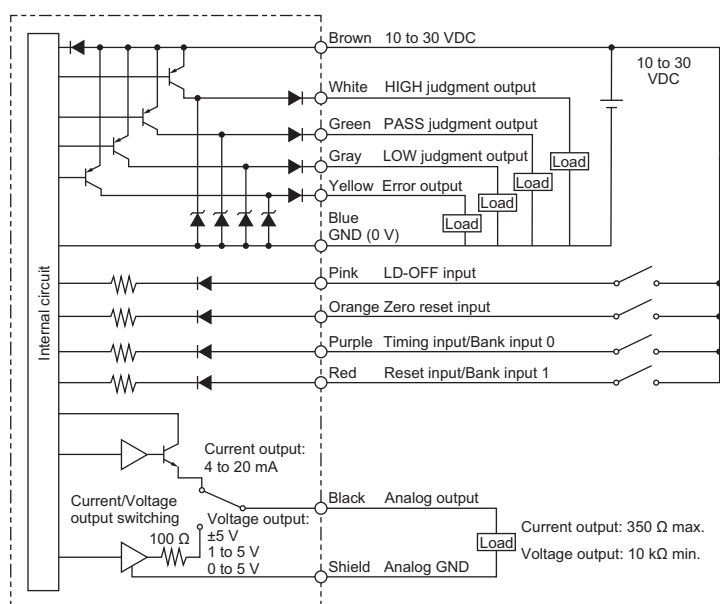

Item	ZP-L3050/ZP-L3550	ZP-L3060/ZP-L3560
Power consumption *1	2,300 mW max.	2,000 mW max.
Control output	Open collector output: 30 VDC, 50 mA max. (20 mA per channel when 5 or more additional slave units are installed) Residual voltage: 2 V max.	
External input	When ON: Power supply voltage short-circuit or within -1.2 V of power supply voltage When OFF: Open (Leakage current: 0.1 mA max.)	
Analog output	Current output: 4 to 20 mA (Maximum load resistance: 350 Ω) Voltage output: ±5 V, 1 to 5 V, 0 to 5 V (Output impedance: 100 Ω)	No analog output

*1. This includes the power consumption of the Sensor Head. It does not include the load current of each output. The power consumption of the ZP-L3590 is 2,000 mW max.

ZP-L3930-IL3/ZP-L3931-IL3 (IO-Link Communication Type)

• Input/output circuit

When using pin 2 (white wire) as the output

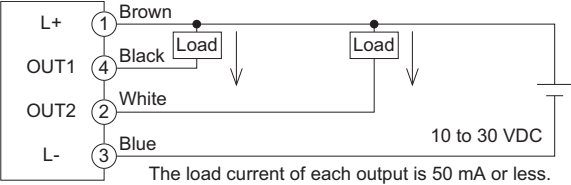
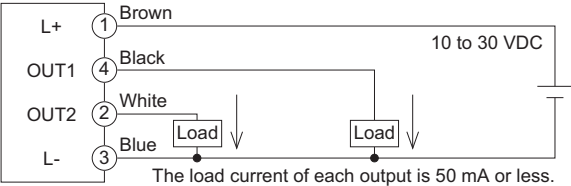
Output method	Input/output circuit diagram
NPN Standard I/O mode *1	
PNP Standard I/O mode *1	

When using pin 2 (white wire) as the external input

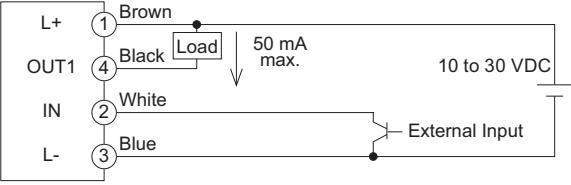
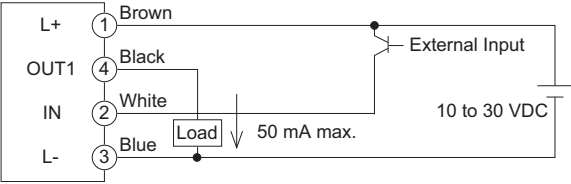
Output method	Input/output circuit diagram
NPN Standard I/O mode *1	
PNP Standard I/O mode *1	

When using in connection with an IO-Link master

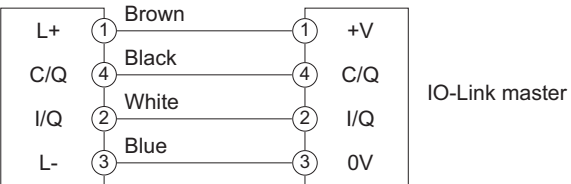
Output method	Input/output circuit diagram
PNP IO-Link mode *2	

NPN/PNP setting	When NPN is set	When PNP is set
Power consumption	2,000 mW max.	
Control output	Open-collector output: 30 VDC (Class 2), 50 mA max. Residual voltage: 2 V max.	
External input	When ON: 0 V short-circuit or 1.5 V max. When OFF: Open (Leakage current: 0.1 mA max.)	When ON: Power supply voltage short-circuit or within -1.5 V of power supply voltage When OFF: Open (Leakage current: 0.1 mA max.)

*1. The standard I/O mode is used for ON/OFF input and output.

*2. The IO-Link mode is used by communicating with the IO-Link master.

The C/Q is used for IO-Link communications. I/Q is used for input or output of ON/OFF.

You can switch between input/output with the operation buttons or the IO-Link communications command.

Wiring

ZP-L30□□/ZP-L35□□

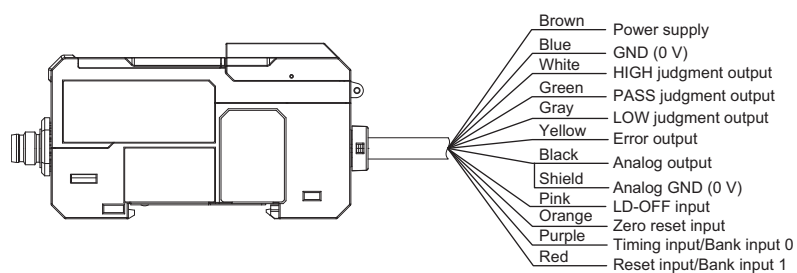

ZP-L3010/ZP-L3060 does not have black (analog output/GND).

ZP-L3500/ZP-L3550 does not have brown (power supply) and blue (GND).

ZP-L3510/ZP-L3560 does not have black (analog output/GND), brown (power supply), and blue (GND).

ZP-L3590 does not have power supply or input/output lines.

ZP-L39□□-IL3

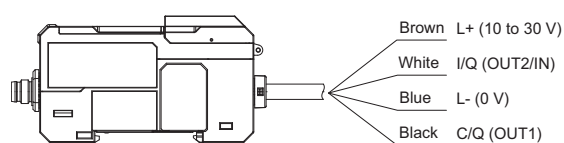

ZP-L3930-IL3 (Cable pull-out type)

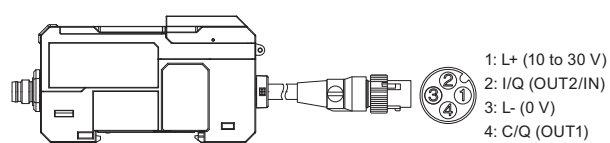

ZP-L3931-IL3 (Pre-wired Connector type)

ZP-LS300□
ZP-LS600□

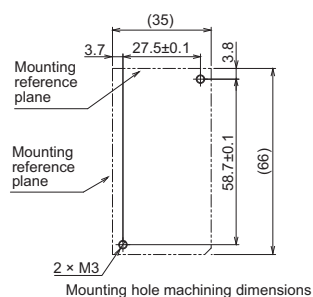

Mounting hole machining dimensions

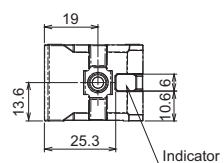
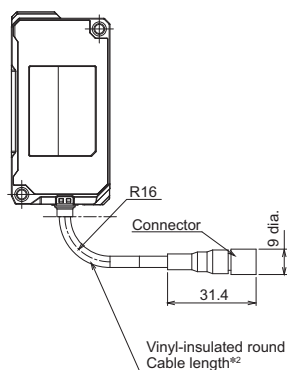
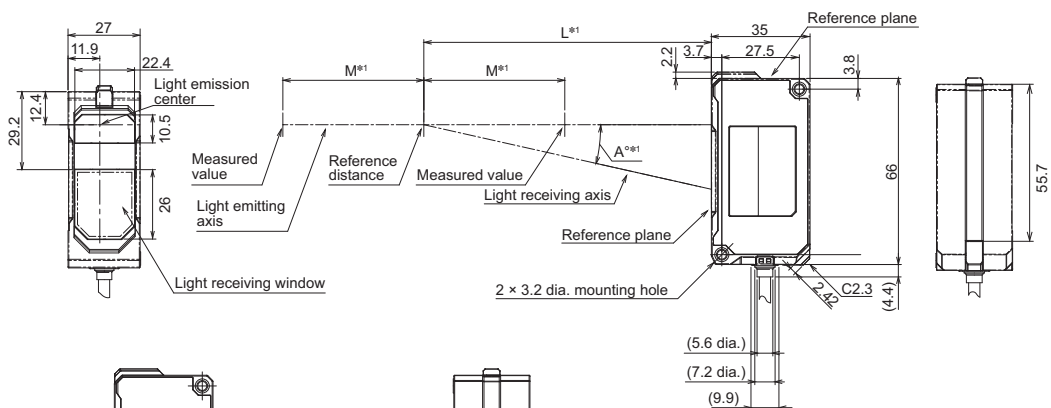
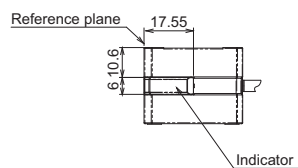

*1.	Model	L	M	A
	ZP-LS300□	300	150	5.91
	ZP-LS600□	600	400	2.95

*2.	Length specification	Standard length (mm)
	0.2 M	(260)
	2 M	(2000)

Amplifier unit Master unit ZP-L30□□

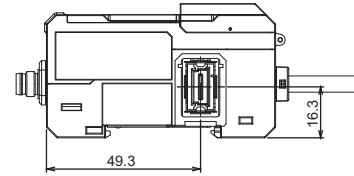
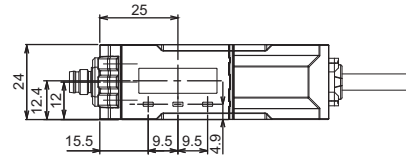

Amplifier Unit connector position

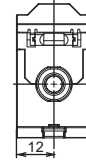
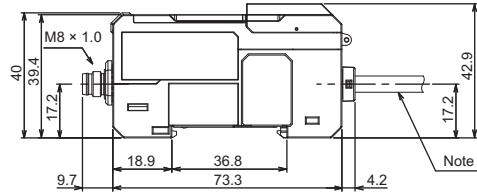

XS3W connector cable socket (straight)

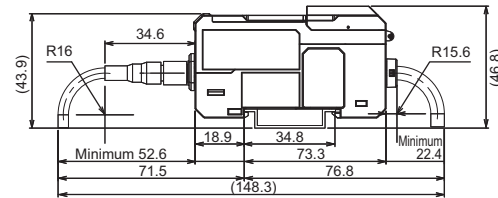

When ZP-LS□ and extension cable (XS3W-M421/M423-□-R) are connected

XS3W connector cable socket (L shape)

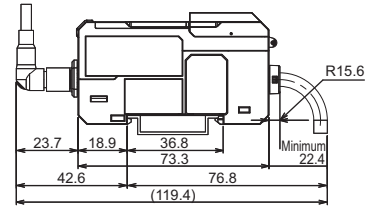

When extension cable (XS3W-M422/M424-□-□) is connected

XS3W connector cable socket (straight)

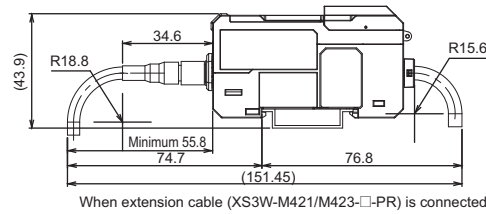

When extension cable (XS3W-M421/M423-□-PR) is connected

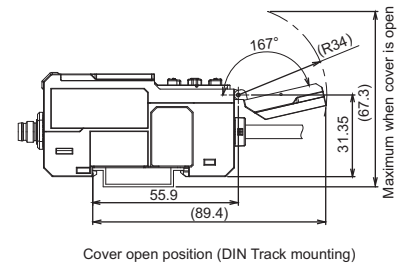

Cover open position (DIN Track mounting)

Note: The cable specifications are as follows:
The table below does not include information on shielding (analog output (0 V)).

Model	Cable outside diameter	Number of conductors	Insulator diameter (mm)		Conductor cross-section (mm ²)		AWG size		Cable length
			Brown/Blue/Black	Others	Brown/Blue/Black	Others	Brown/Blue/Black	Others	
ZP-L3000	5.2 mm dia.	11	1.1±0.1	0.7±0.05	0.22 *1	0.09	24	28	2 m
ZP-L3010		10							
ZP-L3050		11							
ZP-L3060		10							

*1. Black wire not provided for ZP-L3010 and ZP-L3060

Slaver unit
ZP-L3500
ZP-L3510
ZP-L3550
ZP-L3560

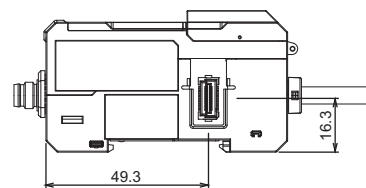
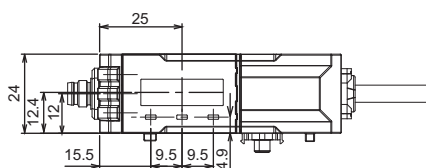

Amplifier Unit connector position

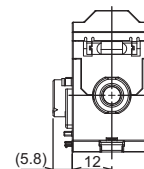
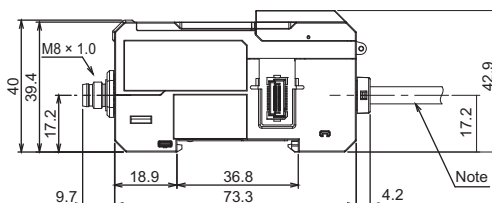

Note: The cable specifications are as follows:

Model	Cable outside diameter	Number of conductors	Insulator diameter (mm)		Conductor cross-section (mm ²)		AWG size		Cable length
			Black	Others	Black	Others	Black	Others	
ZP-L3510	5.2 mm dia.	8	---	---	0.09	---	28	---	2 m
ZP-L3560									
ZP-L3500		9	1.1±0.1	0.7±0.05	0.22	0.09	24	28	
ZP-L3550									

ZP-L3590

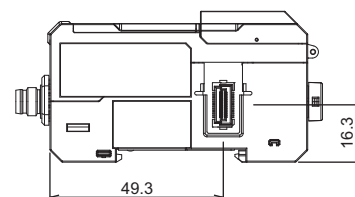
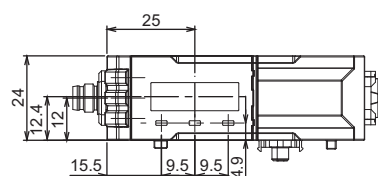

Unit coupling connector position

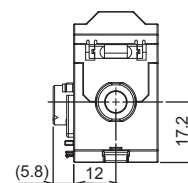
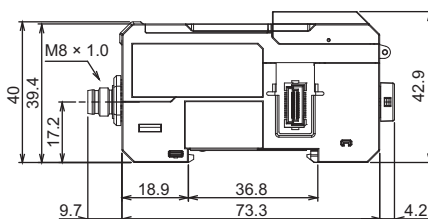

IO-Link Compatible Amplifier Unit
ZP-L39□□-IL3

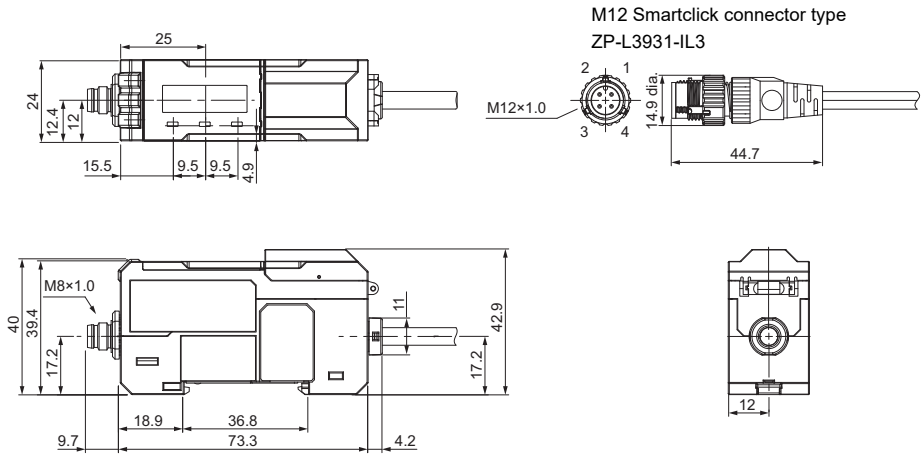

XS3W connector cable socket (straight)

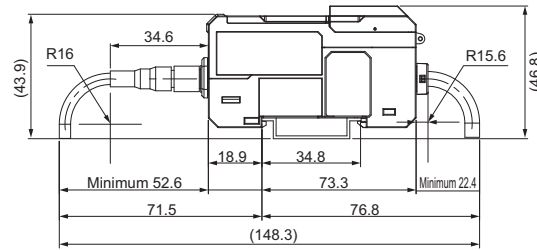

When ZP-LS□ and extension cable (XS3W-M421/M423-□-R) are connected

XS3W connector cable socket (L shape)

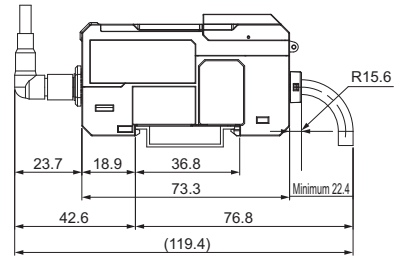

When extension cable (XS3W-M422/M424-□-□) is connected

XS3W connector cable socket (straight)

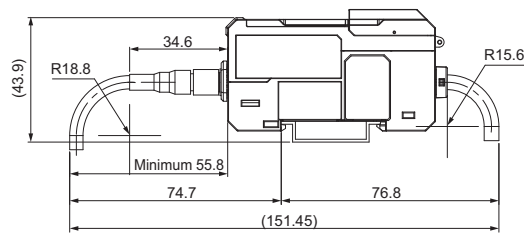

When extension cable (XS3W-M421/M423-□-PR) is connected

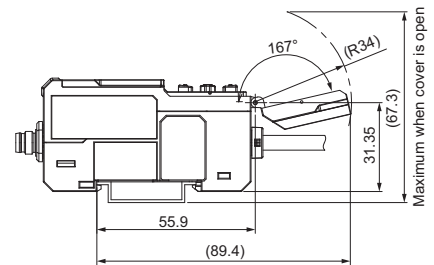

Operating section cover open position (DIN Track mounting)

Note: The cable specifications are as follows:

Model	Cable outside diameter	Number of conductors	Insulator diameter (mm)	Conductor cross-section (mm ²)	AWG size	Cable length
ZP-L3930-IL3	5.2 mm dia.	4	1.1±0.1	0.22	24	2 m
ZP-L3931-IL3						0.3 m

Accessories (sold separately)

Communication Unit

ZP-EIP

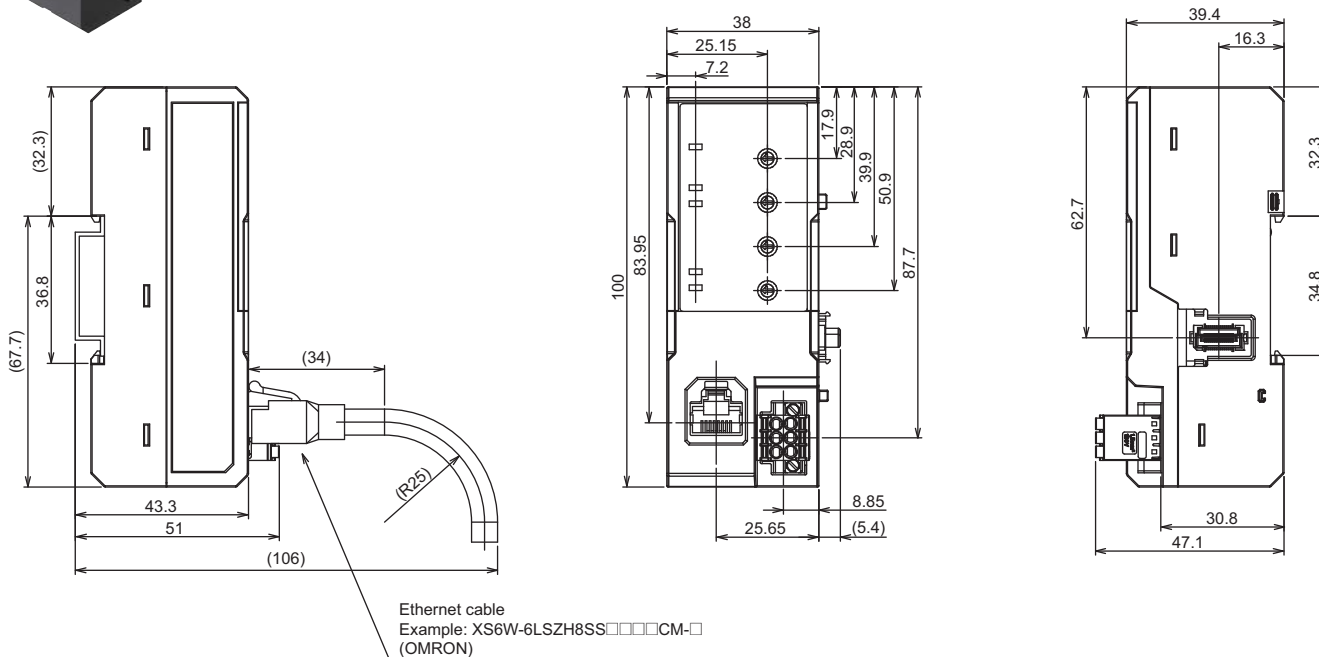

ZP-RSA

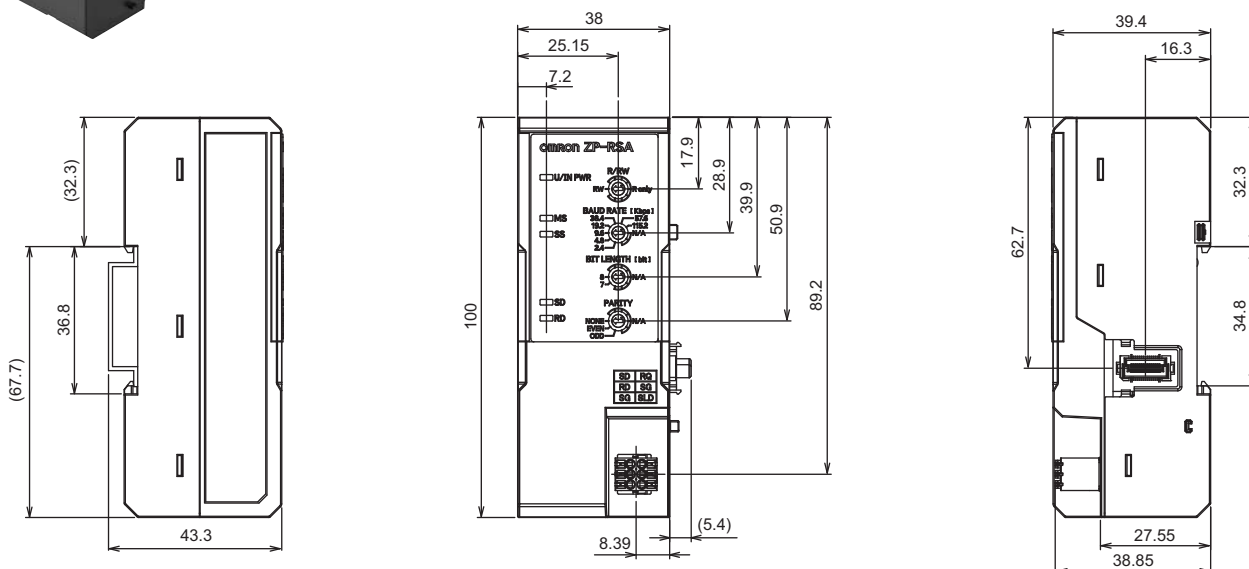

Mounting bracket ZP-XL1



Mounting bracket

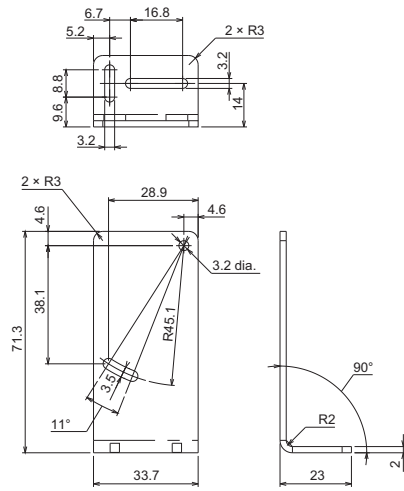

Material: Stainless steel (SUS304)
Weight: Approx. 43 g

Fixing bracket

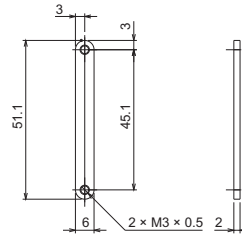

Material: Stainless steel (SUS304)
Weight: Approx. 4 g

ZP-XL2



Mounting bracket

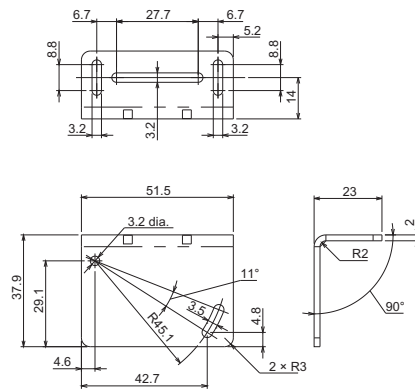

Material: Stainless steel (SUS304)
Weight: Approx. 41 g

Fixing bracket

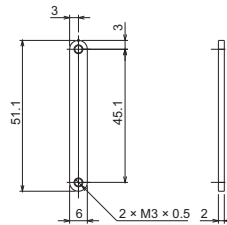

Material: Stainless steel (SUS304)
Weight: Approx. 4 g

ZP-XL3



Mounting bracket

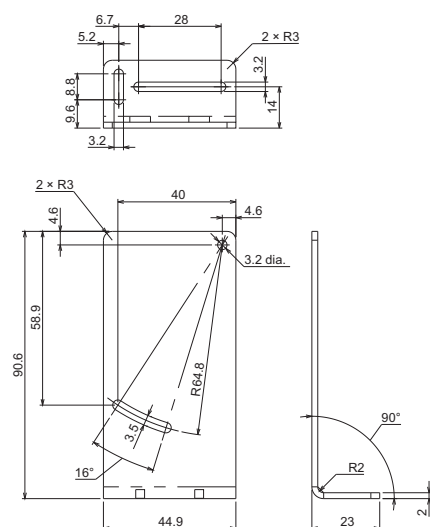

Material: Stainless steel (SUS304)
Weight: Approx. 71 g

Fixing bracket

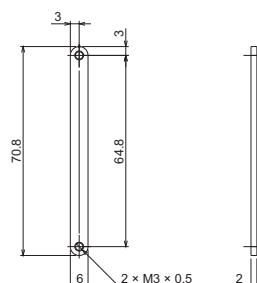

Material: Stainless steel (SUS304)
Weight: Approx. 6 g

ZP-XL4



Mounting bracket

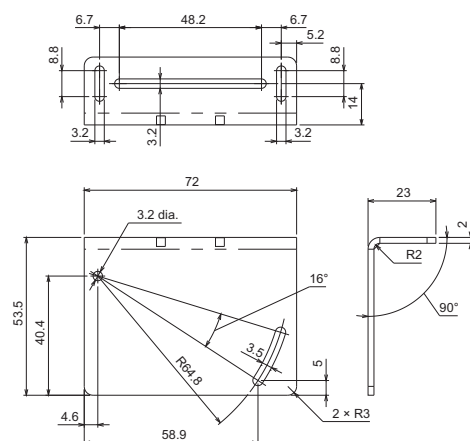

Material: Stainless steel (SUS304)
Weight: Approx. 73 g

Fixing bracket

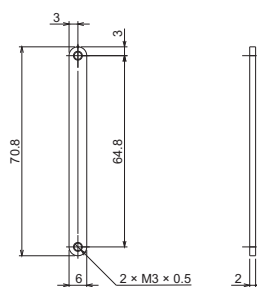

Material: Stainless steel (SUS304)
Weight: Approx. 6 g

ZP-L

ZP-XL5



Clamp

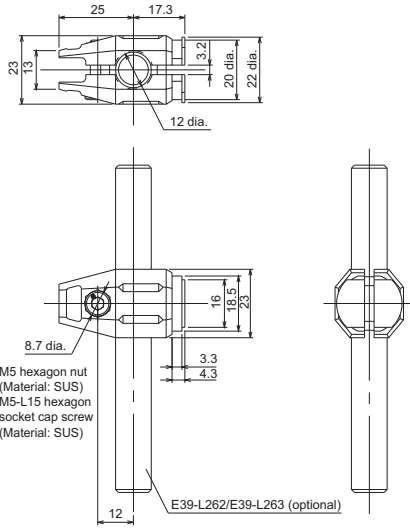

Material: Zinc die casting (ZDC2)
Weight: Approx. 56 g (including clamp fixing screw)

Bracket

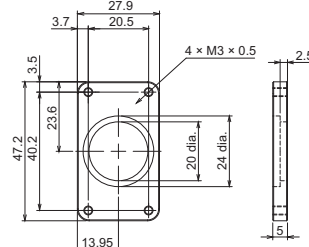

Material: Aluminum (A5052)
Weight: Approx. 12 g

ZP-XL6



Clamp

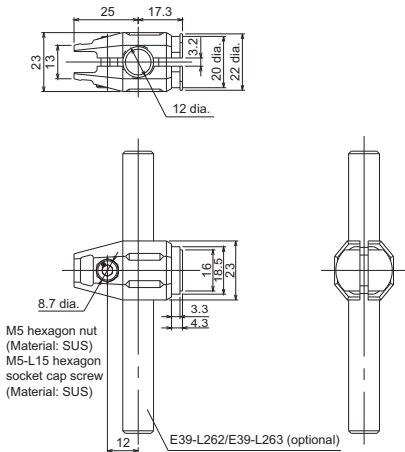

Material: Zinc die casting (ZDC2)
Weight: Approx. 56 g (including clamp fixing screw)

Bracket

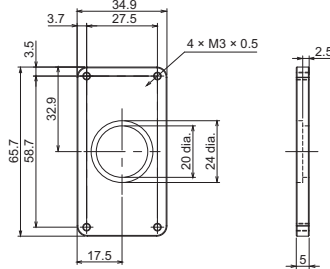

Material: Aluminum (A5052)
Weight: Approx. 25 g

Related Manuals

Man. No.	Model	Manual
Z495	ZP-LS□□/ZP-L3□□□	ZP Series Laser Displacement Sensor User's Manual
Z496	ZP-EIP	ZP-series EtherNet/IP™ Communications Unit
Z499	ZP-RSA	ZP-series RS-232C Communication Unit User's Manual

- EtherCAT® is a registered trademark and patented technology, licensed by Beckhoff Automation GmbH, Germany.
- EtherNet/IP™ is a trademark of ODVA.
- CC-Link IE Field Basic, CC-Link IE Field, and CC-Link IE TSN are registered trademarks of Mitsubishi Electric Corporation and are managed by the CC-Link Partner Association.
- Modbus is a registered trademark of Schneider Electric USA Inc.
- QR code is the registered trademark of DENSO WAVE.
- Microsoft product screen shot(s) reprinted with permission from Microsoft Corporation.
- Other company names and product names in this document are the trademarks or registered trademarks of their respective companies.

Terms and Conditions Agreement

Read and understand this catalog.

Please read and understand this catalog before purchasing the products. Please consult your OMRON representative if you have any questions or comments.

Warranties.

(a) Exclusive Warranty. Omron's exclusive warranty is that the Products will be free from defects in materials and workmanship for a period of twelve months from the date of sale by Omron (or such other period expressed in writing by Omron). Omron disclaims all other warranties, express or implied.

(b) Limitations. OMRON MAKES NO WARRANTY OR REPRESENTATION, EXPRESS OR IMPLIED, ABOUT NON-INFRINGEMENT, MERCHANTABILITY OR FITNESS FOR A PARTICULAR PURPOSE OF THE PRODUCTS. BUYER ACKNOWLEDGES THAT IT ALONE HAS DETERMINED THAT THE PRODUCTS WILL SUITABLY MEET THE REQUIREMENTS OF THEIR INTENDED USE.

Omron further disclaims all warranties and responsibility of any type for claims or expenses based on infringement by the Products or otherwise of any intellectual property right. (c) Buyer Remedy. Omron's sole obligation hereunder shall be, at Omron's election, to (i) replace (in the form originally shipped with Buyer responsible for labor charges for removal or replacement thereof) the non-complying Product, (ii) repair the non-complying Product, or (iii) repay or credit Buyer an amount equal to the purchase price of the non-complying Product; provided that in no event shall Omron be responsible for warranty, repair, indemnity or any other claims or expenses regarding the Products unless Omron's analysis confirms that the Products were properly handled, stored, installed and maintained and not subject to contamination, abuse, misuse or inappropriate modification. Return of any Products by Buyer must be approved in writing by Omron before shipment. Omron Companies shall not be liable for the suitability or unsuitability or the results from the use of Products in combination with any electrical or electronic components, circuits, system assemblies or any other materials or substances or environments. Any advice, recommendations or information given orally or in writing, are not to be construed as an amendment or addition to the above warranty.

See <http://www.omron.com/global/> or contact your Omron representative for published information.

Limitation on Liability; Etc.

OMRON COMPANIES SHALL NOT BE LIABLE FOR SPECIAL, INDIRECT, INCIDENTAL, OR CONSEQUENTIAL DAMAGES, LOSS OF PROFITS OR PRODUCTION OR COMMERCIAL LOSS IN ANY WAY CONNECTED WITH THE PRODUCTS, WHETHER SUCH CLAIM IS BASED IN CONTRACT, WARRANTY, NEGLIGENCE OR STRICT LIABILITY.

Further, in no event shall liability of Omron Companies exceed the individual price of the Product on which liability is asserted.

Suitability of Use.

Omron Companies shall not be responsible for conformity with any standards, codes or regulations which apply to the combination of the Product in the Buyer's application or use of the Product. At Buyer's request, Omron will provide applicable third party certification documents identifying ratings and limitations of use which apply to the Product. This information by itself is not sufficient for a complete determination of the suitability of the Product in combination with the end product, machine, system, or other application or use. Buyer shall be solely responsible for determining appropriateness of the particular Product with respect to Buyer's application, product or system. Buyer shall take application responsibility in all cases.

NEVER USE THE PRODUCT FOR AN APPLICATION INVOLVING SERIOUS RISK TO LIFE OR PROPERTY OR IN LARGE QUANTITIES WITHOUT ENSURING THAT THE SYSTEM AS A WHOLE HAS BEEN DESIGNED TO ADDRESS THE RISKS, AND THAT THE OMRON PRODUCT(S) IS PROPERLY RATED AND INSTALLED FOR THE INTENDED USE WITHIN THE OVERALL EQUIPMENT OR SYSTEM.

Programmable Products.

Omron Companies shall not be responsible for the user's programming of a programmable Product, or any consequence thereof.

Performance Data.

Data presented in Omron Company websites, catalogs and other materials is provided as a guide for the user in determining suitability and does not constitute a warranty. It may represent the result of Omron's test conditions, and the user must correlate it to actual application requirements. Actual performance is subject to the Omron's Warranty and Limitations of Liability.

Change in Specifications.

Product specifications and accessories may be changed at any time based on improvements and other reasons. It is our practice to change part numbers when published ratings or features are changed, or when significant construction changes are made. However, some specifications of the Product may be changed without any notice. When in doubt, special part numbers may be assigned to fix or establish key specifications for your application. Please consult with your Omron's representative at any time to confirm actual specifications of purchased Product.

Errors and Omissions.

Information presented by Omron Companies has been checked and is believed to be accurate; however, no responsibility is assumed for clerical, typographical or proofreading errors or omissions.

Sensors for distance measurement

We offer an array of products for a wide range of detection distances and accuracies.

For detection level difference of around
1 mm

Photoelectric sensor
E3AS-HL series



For resolution of
0.5 μm

Displacement sensor
ZP-L series



For resolution of
0.002 μm

Displacement sensor
ZW series



OMRON AUTOMATION AMERICAS HEADQUARTERS • Chicago, IL USA • 847.843.7900 • 800.556.6766 • automation.omron.com

OMRON CANADA, INC. • HEAD OFFICE

Montreal, Quebec, Canada • 416.286.6465 • 866.986.6766 • automation.omron.com

OMRON MÉXICO • HEAD OFFICE

Mexico City, Mexico • 55 5901 4300 - mela@omron.com

OMRON MÉXICO • GUADALAJARA

Guadalajara, Jal, Mexico • 55.5901.4300

OMRON ELETRÔNICA DO BRASIL LTDA • HEAD OFFICE

São Paulo, SP, Brasil • 55 11 5171-8920 • automation.omron.com

OTHER OMRON LATIN AMERICA SALES

+54.11.4521.8630 • +54.11.4523.8483 • mela@omron.com

Controllers & I/O

- Machine Automation Controllers (MAC) • Motion Controllers
- Programmable Logic Controllers (PLC) • Temperature Controllers • Remote I/O

Operator Interfaces

- Human Machine Interface (HMI)

Motion & Drives

- Machine Automation Controllers (MAC) • Motion Controllers • Servo Systems
- Frequency Inverters

Identification and Vision

- Vision Sensors & Systems • Measurement Sensors • Auto Identification Systems

Sensing

- Photoelectric Sensors • Fiber-Optic Sensors • Proximity Sensors
- Rotary Encoders • Ultrasonic Sensors

Safety

- Safety Light Curtains • Safety Laser Scanners • Programmable Safety Systems
- Safety Mats and Edges • Safety Door Switches • Emergency Stop Devices
- Safety Switches & Operator Controls • Safety Monitoring/Force-guided Relays

Control Components

- Power Supplies • Timers • Counters • Programmable Relays
- Digital Panel Meters • Monitoring Products

Switches & Relays

- Limit Switches • Pushbutton Switches • Electromechanical Relays
- Solid State Relays

Software

- Programming & Configuration • Runtime